

## Quick installation guide

Conveyor system  
MB-flex Q stainless steel

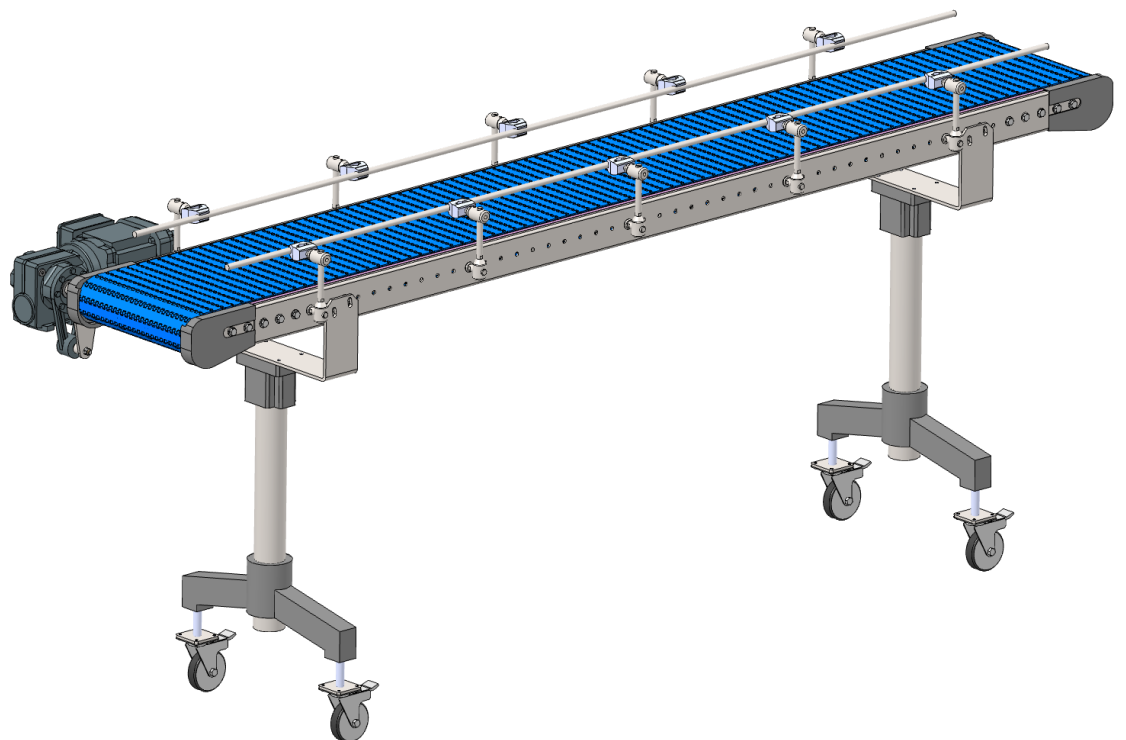

**Conveyor system** MB-flex Q stainless steel

**Publisher** euroflex GmbH  
Hohe-Flum-Strasse 62  
79650 Schopfheim  
Germany  
Tel: + 49 (0) 07622 68 453-30  
Fax: + 49 (0) 07622 68 453-01  
E-Mail: [info@euroflexgmbh.de](mailto:info@euroflexgmbh.de)  
Internet: [www.euroflexgmbh.de](http://www.euroflexgmbh.de)

The document is protected by copyright. All rights are strictly reserved. Copying, reproduction, translation or conversion to an electronic medium or machine-readable form as an entire document or in parts is prohibited without approval of euroflex GmbH.

Subject to modification.

**Suggestions and comments** ... regarding this documentation or the system are to be sent to the address above.

**Last modification** 19.04.2023

# Content

---

<b>1</b>	<b>Reader information .....</b>	<b>4</b>
1.1	Target group .....	4
1.2	Customer service .....	4
1.3	Copyright protection .....	4
<b>2</b>	<b>Safety .....</b>	<b>5</b>
2.1	Owner.....	5
2.2	Obligations of the owner .....	5
2.3	Instruction of the personnel .....	6
2.4	Qualification requirements .....	6
2.4.1	Specially trained personnel.....	6
2.4.2	Operating personnel .....	6
2.4.3	Maintenance personnel.....	6
2.4.4	Qualified specialist personnel .....	6
2.4.5	Electricians.....	7
2.4.6	Specialist pneumatic personnel .....	7
2.4.7	Specialist hydraulic personnel .....	7
2.5	Personal protective equipment .....	7
2.6	Protective enclosure/Protective cover .....	7
2.7	Spare parts and their purchase .....	8
<b>3</b>	<b>Assembly .....</b>	<b>9</b>
3.1	Overview of MB-flex O stainless steel .....	9
3.2	Assembly the chain guide profiles and slide profiles on the modular belt conveyor .....	10
3.2.1	Assembly the chain guide profiles onto the bottom chassis profiles .....	11
3.2.2	Assembly the slide profiles on the modular belt conveyor.....	12
3.3	Assembling the modular chain belt.....	14
<b>4</b>	<b>Cleaning .....</b>	<b>15</b>
4.1	Personnel and Protective equipment.....	15
4.2	Selection of the cleaning agent.....	15
4.3	Preparation .....	16
4.4	Execution .....	16
<b>5</b>	<b>Maintenance .....</b>	<b>17</b>
5.1	Lubrication .....	17
5.2	Maintenance plan.....	18
5.3	Maintenance log.....	20
5.4	Repair .....	20
5.4.1	Conveyor chain: Repair or adjust the chain tension .....	21
<b>6</b>	<b>Table of figures .....</b>	<b>23</b>

# 1 Reader information

This chapter provides information on the usage of the installation guide:

- Target group (Page 4)
- Customer service (Page 4)
- Copyright protection (Page 4)

## 1.1 Target group

This installation guide is intended for the owner, operators and the service personnel.



### Info

The relevant personnel must have specific qualifications in order to work on or with the system. The personnel qualification can be found in the section „Qualification requirements“ (Page 6).

## 1.2 Customer service

Our customer service department will be happy to advise you on technical matters. Information on ordering spare parts can be found in the section “Spare parts and their purchase” (Page 8).

### Customer service

Designation	Specification
Company	euroflex GmbH
Street no.	Hohe-Flum-Straße 62
Postcode, place	79650 Schopfheim
Country	Germany
Telephone	+49 (0) 7622/68453-30
Fax	+49 (0) 7622/68453-01
Email	info@euroflexgmbh.de

## 1.3 Copyright protection

This installation guide is protected by copyright.

The unauthorized forwarding of the installation guide to third parties, reproduction in any type and form, including extracts, as well as the utilization and/or communication of the content are not permitted without the written approval of the manufacturer.

Infringement will lead to compensation for damages. Rights reserved for further claims.

## **2 Safety**

---

This chapter provides information on the safe operation of the conveyor system:

- Owner (Page 5)
- Obligations of the owner (Page 5)
- Instruction of the personnel (Page 6)
- Qualification requirements (Page 6)
- Personal protective equipment (Page 7)
- Protective enclosure/Protective cover (Page 7)
- Spare parts and their purchase (Page 8)

### **2.1 Owner**

The owner is every natural and legal person that uses the conveyor system or permits it to be used by third parties, and who is also responsible for the safety of the user, personnel or third party during usage.

The owner is responsible for the correct assembly and accident-free operation of the system, in accordance with the Machinery Directive 2006/42/EC.

For all work on the conveyor system, the safety regulations resulting from the specifications of the Machinery Directive 2006/42/EC must be implemented and complied with.

### **2.2 Obligations of the owner**

The owner is obliged to implement measures that result from the specifications provided by the Machinery Directive 2006/42/EC.

The safety, accident prevention and environmental protection regulations valid for the conveyor system's area of application must be complied with.

The owner is obliged to do the following in particular:

- Provide information regarding the applicable occupational safety provisions and, via a risk assessment, determine additional dangers that may result due to the special working conditions at the conveyor system's deployment site. He must implement this in the form of operating instructions for the operation of the conveyor system.
- Regularly check the operating instructions and ensure that they correspond to the current status of the regulations.
- Instruct the utilized personnel on possible dangers and the corresponding protective measures. These instructions should be repeated at appropriate intervals.
- Instruct the utilized personnel on handling the conveyor system.
- Equip the utilized personnel with the required protective equipment and check that it is worn at all times.

## 2.3 Instruction of the personnel

Each person assigned to carry out work must, before commencing, receive instruction from the owner regarding their delegated activities and potential dangers during work.

For instruction, observe the following:

- Repeat instruction at regular intervals.
- Verifiably log each personnel instruction session.

## 2.4 Qualification requirements

Safety note: Risk of injury due to insufficient qualification.

If the conveyor system is used improperly, property damage may occur, or persons may be injured or killed.

- » All activities may only be carried out by personnel who have the required training, understanding regarding the functioning of the conveyor system and the relevant experience.

Furthermore, special qualifications are required for certain tasks. These are defined as follows.

### 2.4.1 Specially trained personnel

Specially trained personnel are persons who have been instructed on the tasks delegated to them and their potential dangers by the owner.

### 2.4.2 Operating personnel

Operating personnel are persons who have been instructed on the tasks delegated to them and their potential dangers by the owner. The operating personnel are capable of operating the conveyor system independently. The operating personnel have been instructed regarding possible dangers in the event of improper behaviour. Cleaning and control tasks on the conveyor system are carried out independently.

### 2.4.3 Maintenance personnel

Maintenance personnel are persons who, as a result of their technical training (e. g. mechanical, electrical, pneumatic), knowledge, experience and awareness of pertinent norms and provisions, are capable of correctly carrying out their delegated tasks. Maintenance personnel are capable of recognizing potential dangers independently, and consequently avoiding them.

### 2.4.4 Qualified specialist personnel

Qualified specialist personnel are persons who have obtained and proven special experience, knowledge and skills for the safe performance of tasks in particular specialist areas (e. g. mechanical, pneumatic, hydraulic, electrical) and who fulfil the following defined requirements.

### **2.4.5 Electricians**

Electricians are persons who, as a result of their technical training, knowledge, experience and awareness of pertinent norms and provisions, are capable of correctly carrying out work on electrical systems. Electricians are capable of recognizing potential dangers independently, and consequently avoiding personal injury and property damage caused by electrical currents.

All work on the electrical equipment may only be carried out by electricians.

### **2.4.6 Specialist pneumatic personnel**

Specialist pneumatic personnel are persons who, as a result of their technical training, knowledge, experience and awareness of pertinent norms and provisions, are capable of correctly carrying out work on pneumatic systems. Specialist pneumatics personnel are capable of recognizing potential dangers independently, and consequently avoiding personal injury and property damage caused by pneumatic systems.

All work on pneumatic equipment may only be carried out by specialist pneumatic personnel.

### **2.4.7 Specialist hydraulic personnel**

Specialist hydraulic personnel are persons who, as a result of their technical training, knowledge, experience and awareness of pertinent norms and provisions, are capable of correctly carrying out work on hydraulic systems. Specialist hydraulic personnel are capable of recognizing potential dangers independently, and consequently avoiding personal injury and property damage caused by hydraulic systems.

All work on hydraulic equipment may only be carried out by specialist hydraulic personnel.

## **2.5 Personal protective equipment**

Wearing personal protective equipment is an important element of safety. Missing or unsuitable personal protective equipment increases the risk of health damage and personal injury.

## **2.6 Protective enclosure/Protective cover**

The conveyor system must be equipped with a protective enclosure/cover in areas where there is a danger to persons. The protective enclosure/cover protects the operator and other persons from injuries caused by danger points inside the enclosure/cover.

The owner is responsible for equipping the system with a protective enclosure/cover.

## 2.7 Spare parts and their purchase

Spare parts and accessories can be ordered directly from the manufacturer via the following contact.

### Spare parts: Contact

Designation	Specification
Company	euroflex GmbH
Street no.	Hohe-Flum-Straße 62
Postcode, place	79650 Schopfheim
Country	Germany
Telephone	+49 (0) 7622/68453-00
Fax	+49 (0) 7622/68453-01
Email	info@euroflexgmbh.de



### 3 Assembly

This chapter provides information on the assembly of the conveyor system:

- Overview of MB-flex O stainless steel (Page 9)
- Assembly the chain guide profiles and slide profiles on the modular belt conveyor (Page 10)
- Assembling the modular chain belt (Page 14)

#### 3.1 Overview of MB-flex O stainless steel



Fig. 1: Overview of MB-flex O stainless steel (example)

**Legend**

No.	Designation
1	Modular chain belt
2	Side guide
3	Support
4	Motor

## Information

Data	Designation or value
Personnel	Maintenance personnel
Personal protective equipment	Protective work clothing Protective gloves Safety shoes
Tools, aids	Mitre cutter Steel pin (Ø 4 mm x approx. 200 mm long) Hammer Plastic mallet Carpet knife Drill and drill bit Ø 3.4 mm

**WARNING****Risk of injury and serious damage to property due to improper installation!**

A lack of knowledge about the system and experience in assessing and averting residual risks during proper assembly can result in injury and even death.

- » Before working on the system, turn it off and guard it from being switched back on.
- » Prior to working in the system area, empty or clear the system.
- » Regularly remove product residues and splitters from the entire system area.
- » Check that the screw connections on all load-bearing and moving parts are tightened correctly
- » Check correct function of bearings and links.
- » Check the function of the safety devices.
- » Wear appropriate personal protective gear in the system area.

## Prerequisite:

- System is switched off and safeguarded against being restarted.

### 3.2 Assembly the chain guide profiles and slide profiles on the modular belt conveyor

Observe the following during assembly:

- During assembly, align the butt joints of the components.
- Avoid steps between the butt joints.

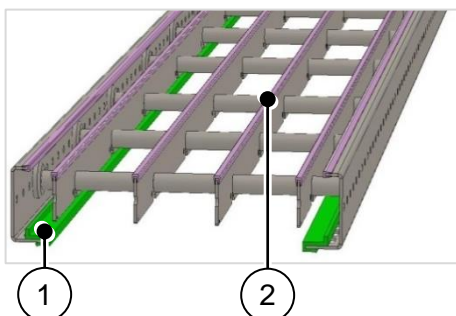

1. Fit the chain guide profiles (1) onto the bottom of the chassis profiles as shown.
2. Fit the slide profiles (2) onto the top of the holding profiles.

Fig. 2: Assembly the chain guide profiles and slide profiles on the modular belt conveyor

### 3.2.1 Assembly the chain guide profiles onto the bottom chassis profiles

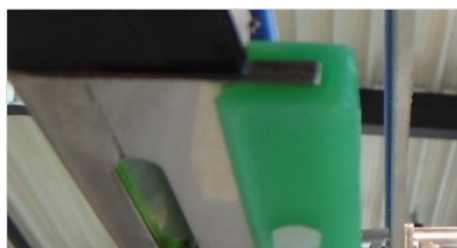
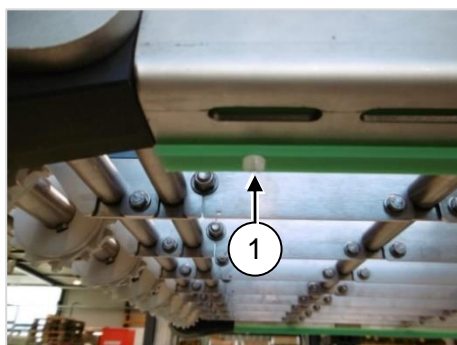
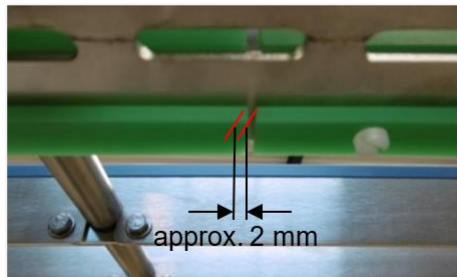
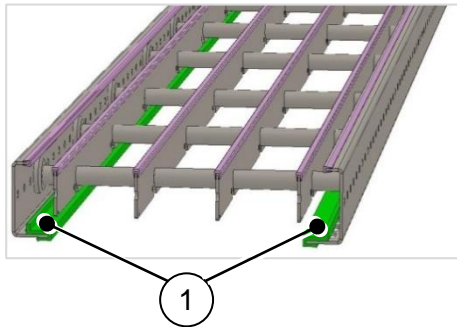

1. Fit the chain guide profiles (1) onto the bottom of the chassis profiles as shown.
2. Press the chain guide profile onto the chassis profile in running direction as far as the stop with the bead downwards (as shown).
  - ! Avoid the development of “waves” in the chain guide profiles by pressing it on completely
3. Check the chain guide profiles for damage.
  - ! Only use undamaged chain guide profiles.
4. Chamfer the chain guide profiles at the start (viewed in running direction).
5. Mount the chain guide profile seams with a gap of approx. 2 mm and offset.
  - ! Always mount the chain guide profiles over the seams of the chassis profile.
6. Cut the chain guide profiles parallel in the running direction.
7. Gently deburr the butt ends.
8. Each profile piece must be fixed at the beginning (viewed in running direction).
9. Using the drill (drill bit  $\varnothing$  3.4 mm), drill a hole in the chain guide profile and chassis profile.
10. Carefully knock in M4 x 8 plastic screw.
  - ! Secure the chassis profile with a support against bending!
11. Deburr after drilling.
12. Remove all chips.
13. Before intermediate elements or subsequent elements, mount the chain guide profile flush with the end of the chassis profile (viewed in running direction).
14. At the end of the conveyor, mount the chain guide profile flush with the drive.

Fig. 3: Assembly of the chain guide profiles onto the bottom chassis profiles

### 3.2.2 Assembly the slide profiles on the modular belt conveyor

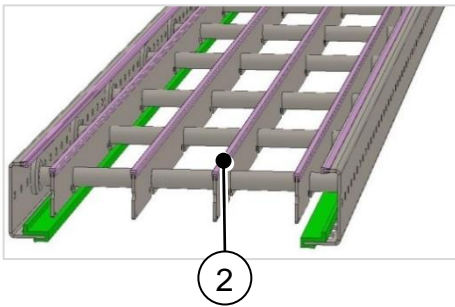

1. Fit the slide profiles (2) onto the top of the holding profiles.



2. Check the slide profiles for damage.  
! Only use undamaged slide profiles.
3. Chamfer the slide profiles at the start (viewed in running direction).



4. Press the slide profiles in the running direction as far as the stop.  
! Avoid the development of "waves" in the slide profiles by pressing it on completely.



5. Press the slide profiles at both ends onto the chassis profile.
6. Press the slide profiles onto the holding profiles as follows:
  - a) With straight holding profiles, press the slide profiles onto the top side.
  - b) With bent holding profiles (in sliding bends), press the slide profiles onto the top and bottom side of the holding profiles.

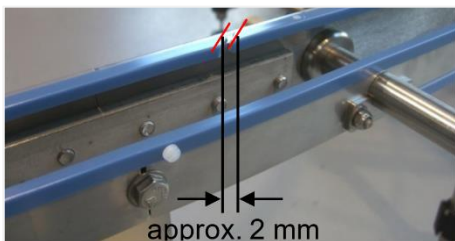

7. Mount the slide profile seams with a gap of approx. 2 mm and offset.
8. Cut the slide profiles at an angle in the running direction.

9. Gently deburr the butt ends.

! Always mount the slide profiles over the seams of the holding profile.

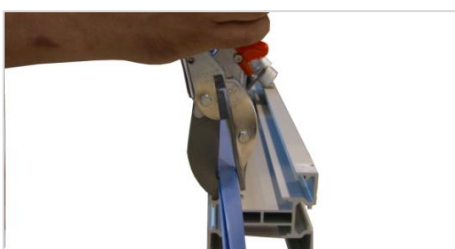

10. Cut the slide profile straight at the end of the holding profile (viewed in running direction) and press it on flush.
11. Gently deburr the butt ends.

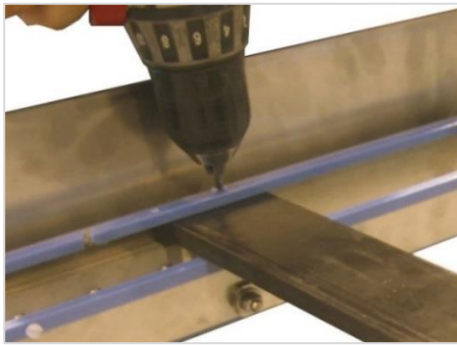

12. Each slide profile piece must be fixed at the beginning (viewed in running direction).
13. Using the drill (drill bit  $\varnothing$  3.4 mm), drill a hole in the slide profile and holding profile.

! Secure the profile with a support against bending!

14. After drilling, deburr and remove all chips.

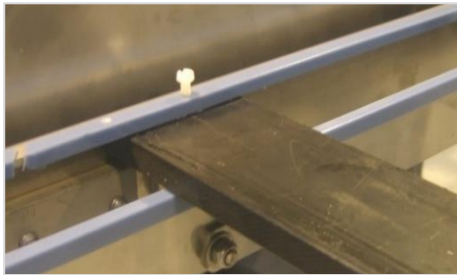

15. Carefully knock in M4 x 8 plastic screw.

! Secure the profile with a support against bending!



16. With holding profiles where the conveyor chain lies on (chain running surfaces), cut the screw head carefully and flush.
17. Rework possible supernatants with the file.



18. With chassis profiles, also cut the screw head carefully from below (chain running surface) and flush.
19. Rework possible supernatants with the file.

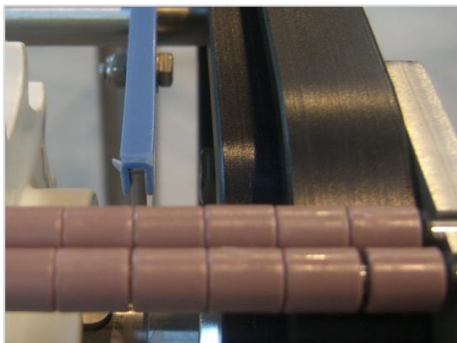

20. Before intermediate elements or subsequent elements, mount the slide profile flush with the end of the holding profile (viewed in running direction).
21. At the end of the conveyor, mount the slide profile flush with the drive.

Fig. 4: Assembly the slide profiles on the modular belt conveyor



### 3.3 Assembling the modular chain belt

Observe the following during assembly:

- Select the chain length so that the contraction of the chain ends is done with little effort.
  - ! With a tight chain, rattling will be heard at the drive station.



1. Check the run using a short piece of the chain.
2. Remove any clamping points and rework seams if necessary.
3. Insert the chain centrally into the deflection and push/pull until the chain has been completely pulled through the conveyor.

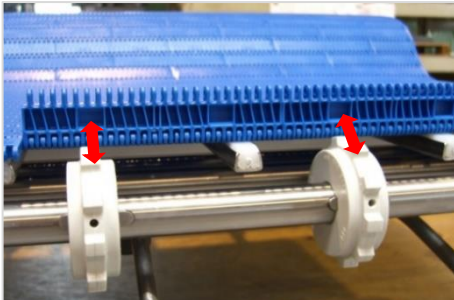

4. To ensure that the sprockets engage exactly with the chain, mount the sprockets in the same position as the recesses in the chain.

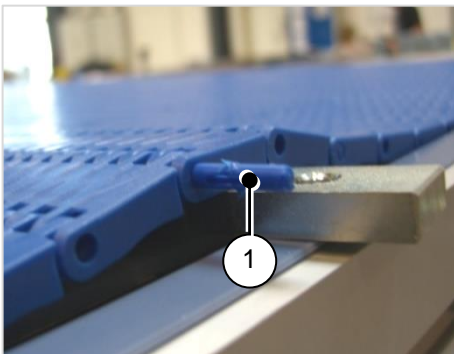

5. Join the chain ends together.
6. Insert the connecting rod (1) (locking bead last) and knock it in carefully.

Fig. 5: Assembling the modular chain belt

## 4 Cleaning

This chapter provides information on the execution of the operating mode Cleaning:

- Personnel and Protective equipment (Page 15)
- Selection of the cleaning agent (Page 15)
- Preparation (Page 16)
- Execution (Page 16)

### ATTENTION

#### Warning of material damage due to improper cleaning!

Improper cleaning leads to damage to the system or its surroundings.

- » Cleaning the system according to the instructions in this installation guide.
- » Do not use steam jet or high-pressure cleaning devices for cleaning surfaces.
- » Do not use compressed air for cleaning and drying surfaces.

### 4.1 Personnel and Protective equipment

Personnel and Protective equipment

Specification	Designation
Personnel	Operating personnel
Personal protective equipment	Protective equipment against the cleaning agents used according to the instructions of the manufacturer of the cleaning agents

### 4.2 Selection of the cleaning agent

The cleaning agents used are specified by the local hygiene officer.

Observe the cleaning agent manufacturer's instructions.

Furthermore, observe the following:

Find application:

- Solutions with a pH value between 4.5 and 9
- Water under low pressure
- Water with temperatures below 40°C

Find no application:

- Cleaning products containing chlorine, ammoniac, phosphoric acid or their compounds
- Abrasive cleaning products
- Solutions with a pH value below 4.5 or above 9
- Water under high pressure
- Water with temperatures above 40°C

### 4.3 Preparation

Carry out the following work steps:

1. Switch off the conveyor system.
  - ▼ No voltage is present at the conveyor system.
2. Close the pneumatic supply at the main valve and secure it with a personal padlock.
3. Secure the main switch on the control cabinet with a personal padlock.

The conveyor system is prepared for cleaning.

✓ **Ready.**

### 4.4 Execution

Prerequisite:

- Conveyor system is switched off and secured against being switched on again
- Conveyor system is prepared for cleaning

Carry out the following work steps:

1. Remove residues of conveyance goods.
2. Remove contamination without damaging the surface.
3. Remove contamination with cleaning agents.
4. Rinse off solution with water under low pressure.
5. Rub surface to dry it.

✓ **Ready.**

Contact euroflex GmbH for instructions on cleaning any further contaminants.



## 5 Maintenance

This chapter provides information on the maintenance work to be carried out:

- Lubrication (Page 17)
- Maintenance plan (Page 18)
- Maintenance log (Page 20)
- Repair (Page 20)

### 5.1 Lubrication

Incorrect or negligent use of hazardous substances may lead to serious environmental pollution.

Observe the following:

- Apply lubricant evenly and sparingly at the specified points.
- Carefully remove any escaping, used or excess lubricant.
- Deal with solvents and cleaning agents in accordance with the manufacturer's safety data sheet.
- Dispose of all hazardous substances in accordance with the regional guidelines and commission a specialist company if required.

Malfunctions and excessive levels of wear on individual components are likely to result from the use of operating substances that cause significant pollution and/or that fail to comply with the stipulated specification. Warranty claims that can be traced back to this content shall be rejected.

Observe the following:

- Use operating substances with the specified purity class.
- Check the state of the operating substance at regular intervals.

#### Lubrication schedule

No.	Designation			
	Name	Note	Interval [Bh]	Lubricant
1	Roller chain (Drive)	Spray!	250 also after each cleaning	Chain Lubricant Spray NSF H1
2	Drive station, Deflection, Sliding bend, Bending wheel	Spray!	250 also after each cleaning	Silicone spray NSF H1
3	Gear motor (Drive motor)	Details on lubrication and maintenance see manufacturer of the gearmotor		

## 5.2 Maintenance plan

Regular maintenance and care are required for the operational safety and fault-free operation of the system. The specifications in the maintenance plan are guide values and must be adjusted by the owner depending on the operating conditions.

### ATTENTION

#### Warning of material damage due to non-original spare parts!

Use of non-original spare parts can lead to defects in the conveyance goods, operational malfunctions, loss of safety functions and damage to or destruction of components.

» Only replace components with original spare parts from euroflex GmbH.

#### General

Assembly and maintenance work		Interval [Bh]	Personnel
Inspect the conveyor system for visible damage, noise and vibration		8 (per shift)	Operating personnel
Safety and protective devices	Check for completeness and function	8 (per shift)	Operating personnel
	Replace defective equipment	Replace if required	Maintenance personnel
Operating and display elements (buttons, switches, indicator lamps, manometers)	Check functionality	24 (daily)	Operating personnel
	Replace defective components	Replace if required	Maintenance personnel
Signage	Check legibility and completeness	24 (daily)	Operating personnel
	Clean or replace, if required	Replace if required	
Check fixing elements, retighten if required		1.000 (quarterly)	Maintenance personnel
Check the supply lines and connections for leakage		after the first 20	Maintenance personnel
		24 (daily)	
Electrical connections	Check for damage and firm seating	24 (daily)	Electricians
	Replace defective connections	Replace if required	
Adhere to lubrication schedule		"Lubrication schedule" (Page 17)	Maintenance personnel
Clean conveyor system		24 (daily)	Operating personnel

**Conveyor system**

Assembly and maintenance work		Interval [Bh]			Personnel
Remove foreign bodies		8 (per shift)			Operating personnel
Clean conveyor system surface		8 (per shift)			Operating personnel
Check gear unit for leakage		8 (per shift)			Maintenance personnel
Inspect surface for damage		170			Maintenance personnel
Conveyor chain	check for damage and elongation	50	250	500	Maintenance personnel
		thereafter every 500			
	replace	4,000			
Slide profiles	check for damage and wear	50	250	500	Maintenance personnel
		thereafter every 500			
	replace	4,000			
	Check all connections				
Check bending wheel for damage and wear		500			Maintenance personnel
Check sliding bend for damage and wear		500			Maintenance personnel
Check roller transition/end module for damage and wear		500			Maintenance personnel
Flange bearing: Check eccentric ring for secure seating		170			Maintenance personnel
Check motor plate for secure seating		500			Maintenance personnel
Check bearing and links for correct function		1,000 (quarterly)			Maintenance personnel
Check toothed wheel for damage and wear		50	250	500	Maintenance personnel
		thereafter every 500			

**Drive/Deflection unit**

Assembly and maintenance work		Interval [Bh]			Personnel
Guides of the conveyor chain (KU side parts)	check for damage and wear	1,000 (quarterly)			Maintenance personnel
	replace	7,000			
Sprocket wheel/ Deflection pulley	check for damage and wear	1,000 (quarterly)			Maintenance personnel
	replace	7,000			
Ball bearing	replace	7,000			Maintenance personnel
Sheet metal flange bearing	replace	7,000			Maintenance personnel
Roller chain at the drive station	check for damage and wear	50	250	500	Maintenance personnel
		thereafter every 500			
Sprocket wheel on roller chain	check for damage and wear	1,000 (quarterly)			Maintenance personnel
	replace	7,000			

Electrical system

Assembly and maintenance work	Interval [Bh]	Personnel
Check electrical wiring for visible damage	40	Electricians
Electrical connections and distributors: Check terminal boxes for damage	170	Electricians

### 5.3 Maintenance log

The required maintenance intervals are dependent on the intensity of use of the system at the owner’s deployment site and the consequent signs of wear. In order to be able to adjust the maintenance intervals of these terms of use, the general condition of the system as a whole as well as the assemblies and components must be logged in detail during the regular and (if required) unscheduled maintenance work.

Observe the following when creating maintenance logs:

- Produce a maintenance log for each maintenance task and log all performed maintenance work.
- Store the maintenance logs.

### 5.4 Repair

Incorrect repair work impairs the operational safety. This can cause accidents and seriously injure people as a result.

Observe the following:

- Repair work may only be carried out by the manufacturer or authorized specialist personnel.
- Switch off the system and secure it against being switched back on before all repair work.
- Switch off the compressed air system and secure it against being switched back on. Depressurize the compressed air-conveying components. Check if the pneumatic system has been relieved of pressure.
- Work on the electrical system may only be carried out by trained electricians.
- For all work on the electrical system, switch off the voltage supply and secure it against being switched back on again by accident.
- Only use original spare parts.

In case of repairs at the conveyor system, the customer service will help (see page 4: Customer service).

Spare parts can be ordered directly from the manufacturer (see page 8: Spare parts and their purchase).

Personnel

Specification	Designation
Personnel	Maintenance personnel

#### 5.4.1 Conveyor chain: Repair or adjust the chain tension



### WARNING

#### **Danger to life due to moving machine parts!**

Danger of injury and pulling in due to too long chain sag! Risk of crushing and cutting!

Moving machine parts can cause serious personal injury or death.

- » Prior to starting, ensure that no persons are present in the danger zone.
  - » Do not reach into moving machine parts during operation.
  - » Maintain a safe distance from moving machine parts during operation.
  - » Only carry out repairs, maintenance, cleaning and disassembly work when de-energised.
- 

If one or more chain links are damaged, they must be replaced.

If an uneven running or ambient noise occurs, it is necessary to shorten the chain belt.

Select the chain length so that the contraction of the chain ends is done with little effort.

### 5.4.1.1 Adjust modular belt chain

#### Information

Data	Designation or value
Personnel	Maintenance personnel
Personal protective equipment	Protective work clothing Protective gloves Safety shoes
Tools, aids	Steel pin (Ø 4 mm x approx. 200 mm long) Hammer

#### Prerequisite:

- System is switched off and safeguarded against being restarted.

Perform the following steps:

1. Lift the chain upwards.
2. Carefully knock out the connecting rod (1) with the steel pin (locking bead first) and remove it.

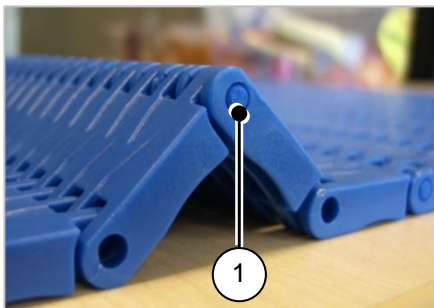

Fig. 6: Adjust modular belt chain

3. Remove corresponding chain links or insert new chain links.
4. Join the chain ends together again.
5. Insert new connecting rod (1) (locking bead last) and knock in carefully.

✓ **Ready.**

## **6 Table of figures**

---

Fig. 1: Overview of MB-flex O stainless steel (example) .....	9
Fig. 2: Assembly the chain guide profiles and slide profiles on the modular belt conveyor .....	10
Fig. 3: Assembly of the chain guide profiles onto the bottom chassis profiles .....	11
Fig. 4: Assembly the slide profiles on the modular belt conveyor .....	13
Fig. 5: Assembling the modular chain belt .....	14
Fig. 6: Adjust modular belt chain.....	22